

SPARE PARTS CATALOGUE

Z560 „BERTA“ BALE WRAPPER

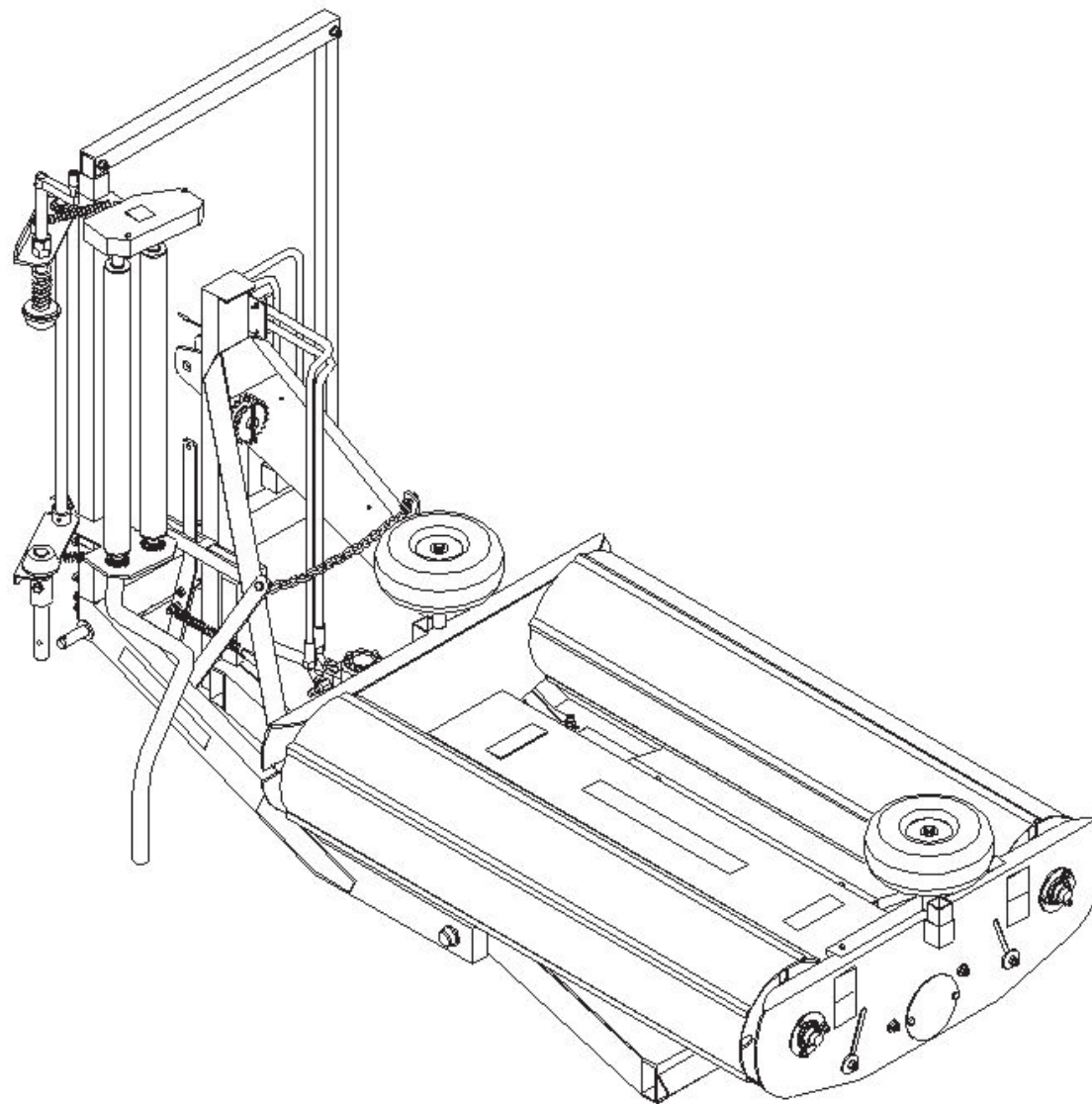

Sokółka 20.....

LIST OF CATALOGUE ITEMS

No.	Table title	Page number
1.	Complete main frame	3
2.	Wrapping foil feeder	7
3.	Stretcher roll, set	11
4.	Complete lower frame with hydraulic system	13
5.	Complete rotary frame	17
6.	Vertical bale positioning device	21

Main frame -1/2

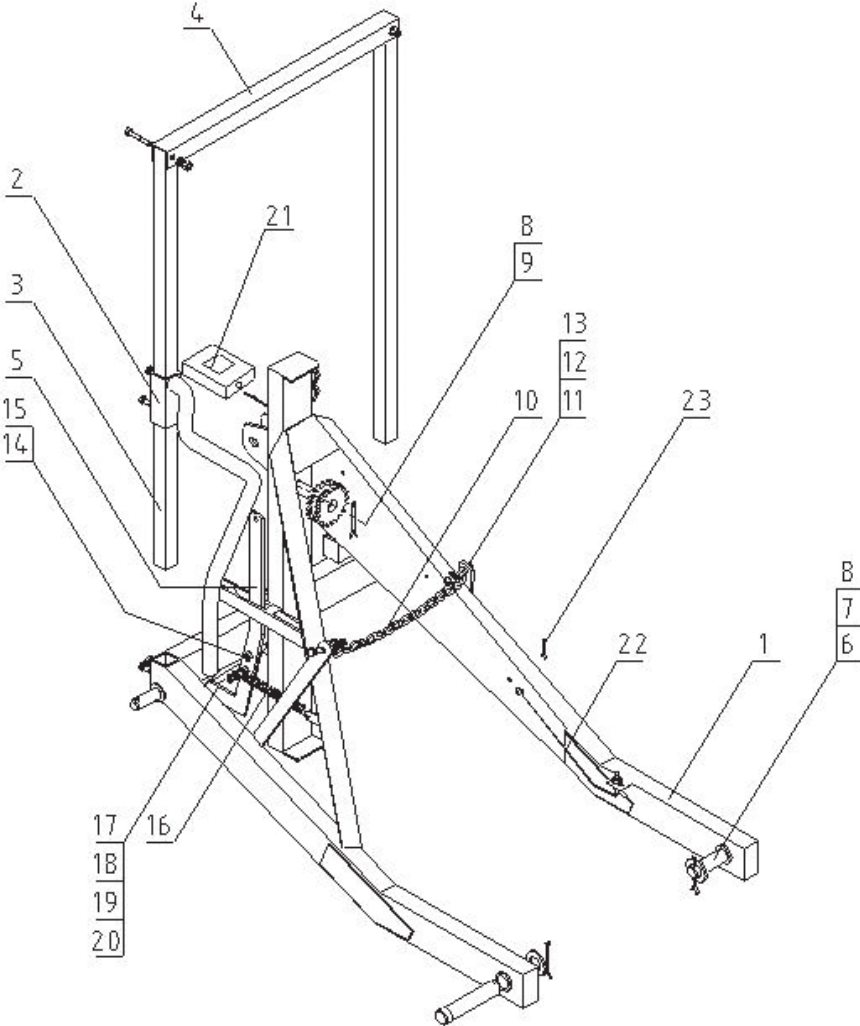

MAIN FRAME 1/2

No. in dwg	Part name	Drawing no. or standard	Quantity
1	Welded frame	Z 560 – 01.01.00	1
2	Railing, set	Z560 – 01.02.00	1
3	Bracket	Z552 – 01.00.03	2
4	Crossbar	Z552 – 01.00.04	1
5	Lever	Z552 – 01.00.05	1
6	Main pin	Z552 – 01.00.07	2
7	Plain washer, Ø37	PN/M – 82005	2
8	Cotter pin, 6.3x71 S – Zn	PN/M – 82001	3
9	Wheel, Z – 16 5/8"	Z 560 – 00.00.19/II	1
10	Farming chain		1
11	Bolt, M12x35 5,8 – B	PN/M – 82105	2
12	Plain washer Ø13	PN/M – 82005	2
13	Nut, M12 5 – B	PN/M – 82175	2
14	Bolt, M12x30 5.8 – B	PN/M – 82105	1
15	Nut, M12 5 – B	PN/M – 82144	1
16	Spring	Z552 – 01.00.07	1
17	Bolt, M12x45 5,8 – B	PN/M – 82105	1
18	Nut, M12 5 – B	PN/M – 82144	1
19	Plain washer Ø13	PN/M – 82005	1
20	Nut, M12 5 – B	PN/M – 82175	1
21	Impulse counter	L – 01	1
22	Counter cable with a sensor		
23	Cotter pin, 2.5x25 S – Zn	PN/M – 82001	3
24	Bolt, M12x70 5.8 – B	PN/M – 82101	3
25	Nut, M12 5 – B	PN/M – 82175	3

Main frame - 2/2

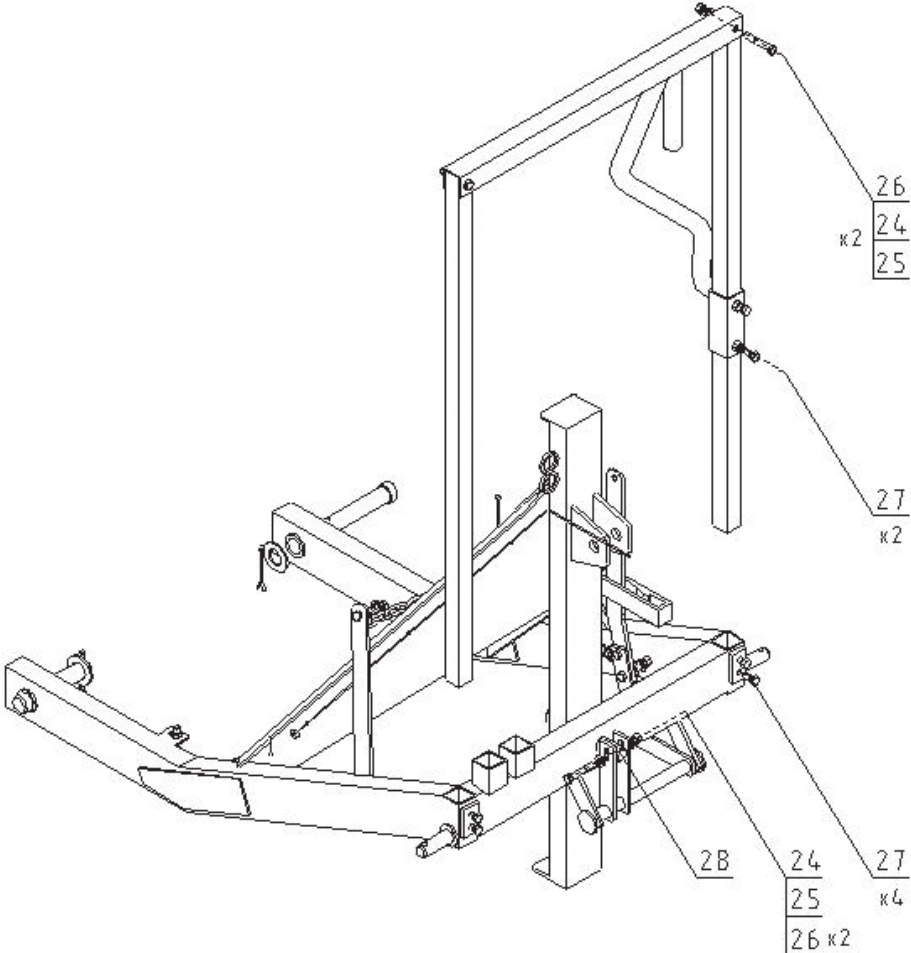

MAIN FRAME 2/2

No. in dwg	Part name	Drawing no. or standard	Quantity
26	Plain washer Ø13	PN/M – 82005	4
27	Bolt, M12x30 5.8 – B	PN/M – 82105	6
28	Lever pin	Z552 – 01.00.06	1

Wrapping film feeder

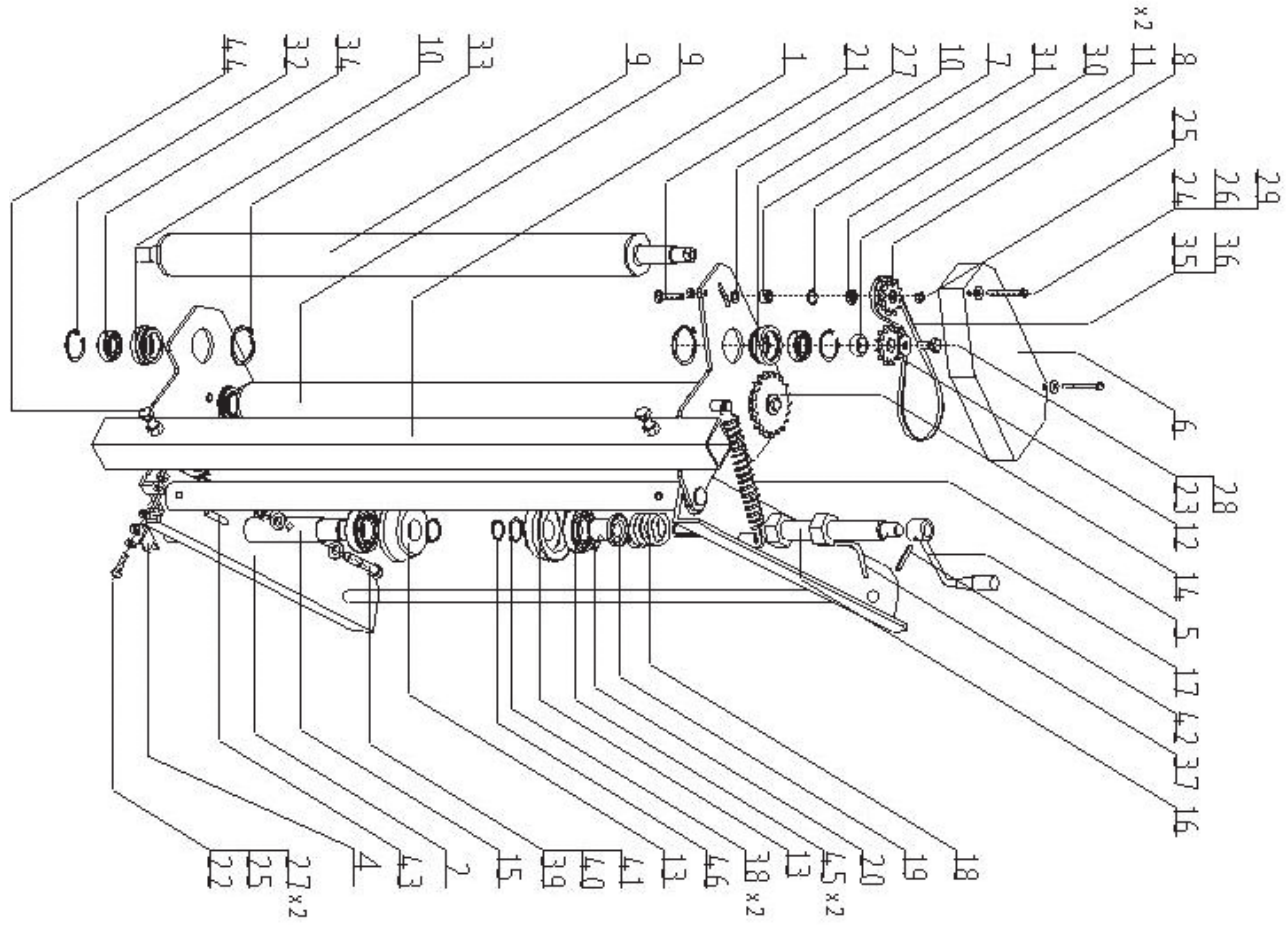

WRAPPING FILM FEEDER 1/2

No. in dwg	Part name	Drawing no. or standard	Quantity
1	Mounting bracket	Z 560 – 02.01.00	1
2	Wrapping film bracket, set	Z560 – 02.02.00	1
3			1
4	Lock	Z 560 – 02.00.04	1
5	Spring I	Z 552 – 02.00.16	2
6	Cover	Z 560 – 02.06.00	1
7	Spacing bushing II	Z 560 – 02.00.08	1
8	Chain wheel, Z – 11	Z 560 – 02.00.09	1
9	Stretcher roll, set	Z560 – 02.24.00	2
10	Roll holder	Z 560 – 02.00.25	4
11	Spacing bushing III	Z 560 – 02.00.26	2
12	Chain wheel, Z – 12	Z 560 – 02.00.30	1
13	Conic film pressure element	Z560 – 02.00.041	2
14	Chain wheel, Z – 21	Z 560 – 02.00.32	1
15	Lower roll	Z 560 – 02.00.35/I	1
16	Adjusting screw	Z 560 – 02.36.00/I	1
17	Handle, set	Z560 – 02.37.00	1
18	Spring II	Z 552 – 02.00.14	1
19	Bushing	Z 560 – 02.00.31	1
20	Lock	Z560 – 02.00.48	1
21	Bolt, M 8x40 5.8 – B	PN/M – 82406	1
22	Bolt, M 8x30 5.8 – B	PN/M – 82105	1
23	Bolt, M10x25 5.8 – B	PN/M – 82105	2
24	Bolt, M6x70 5.8 – B	PN/M – 82175	2
25	Nut, M8 5 – B	PN/M – 82175	2

Wrapping film feeder

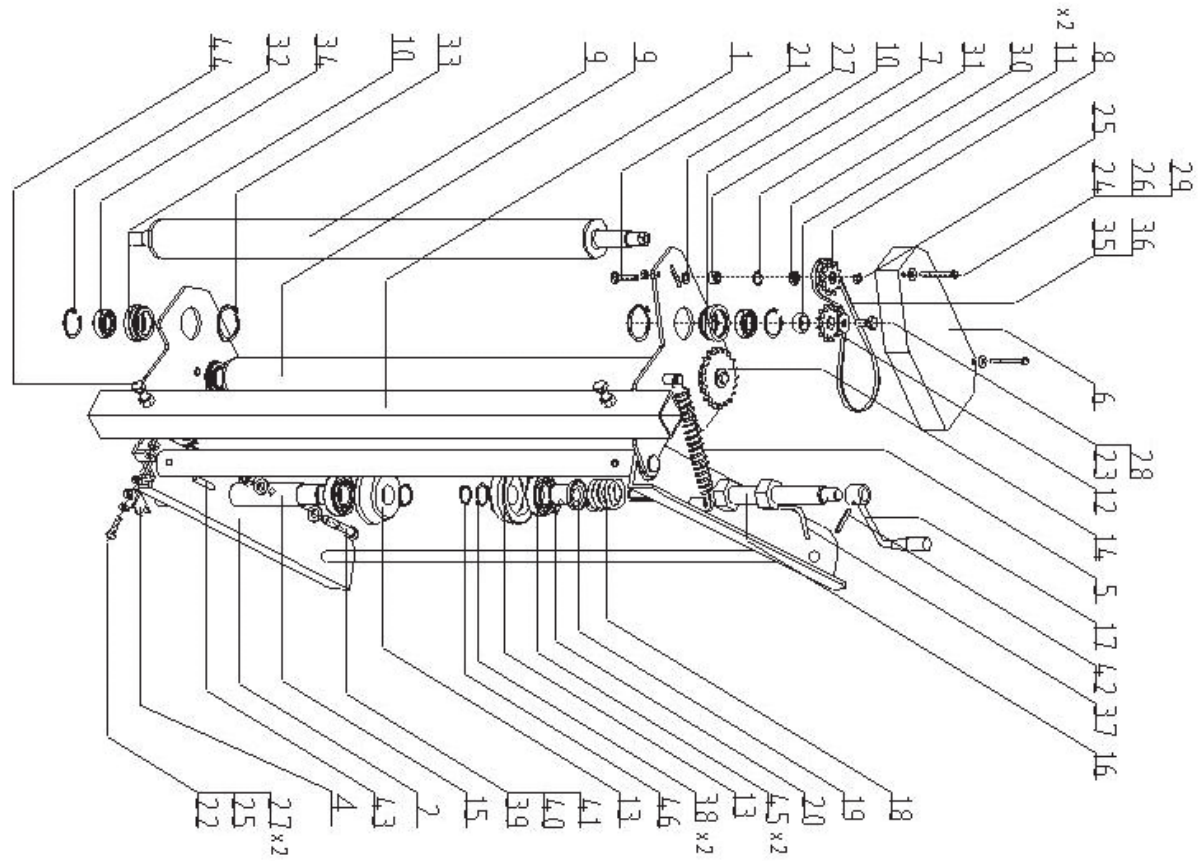

WRAPPING FILM FEEDER 2/2

No. in dwg	Part name	Drawing no. or standard	Quantity
26	Nut, M6 5 – B	PN/M – 82175	2
27	Plain washer Ø8.4	PN/M – 82005	3
28	Plain washer, Ø10.5	PN/M – 82030	2
29	Plain washer Ø6.5	PN/M – 82030	2
30	Bearing, 608Z	PN/M – 86100	1
31	Spring ring, W – 22	PN/M – 85111	1
32	Spring ring, W – 42	PN/M – 85111	4
33	Spring ring, Z – 50	PN/M – 85111	4
34	Bearing, 6004 RS	PN/M – 86100	4
35	Roller chain, 08B ½"	PN/M – 84168	1
36	Fastening link, 08B	PN/M – 84168	1
37	Locknut, M27	Z560 – 02.38.00	1
38	Spring ring, Z – 30	PN/M – 85111	2
39	Bolt, M12x70 5.8 – B	PN/M – 82101	1
40	Nut, M12 5 – B	PN/M – 82175	1
41	Plain washer Ø13	PN/M – 82005	2
42	Spring pin, 6x45	PN/M – 85023	1
43	Spring pin, 8x50	PN/M – 85023	1
44	Bolt, M12x30 5.8 – B	PN/M – 82105	2
45	Bearing, 6206 RS	PN/M – 86100	2
46	Spring ring, Z – 20	PN/M – 85111	1

Stretcher roll, set

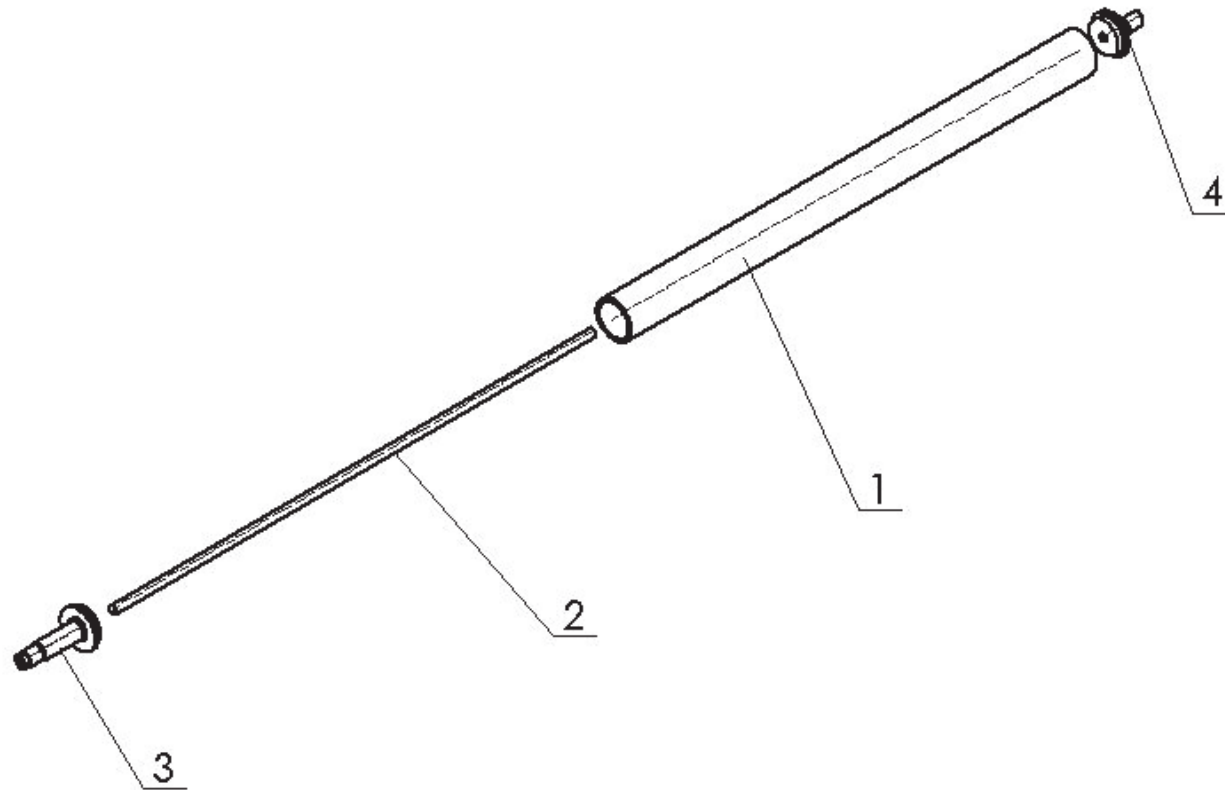

STRETCHER ROLL, SET

No. in dwg	Part name	Drawing no. or standard	Quantity
1	Stretcher tube	Z560 – 02.24.04	1
2	Connecting rod	Z560 – 02.24.02	2
3	Holder I	Z560 – 02.24.03	4
4	Holder II	Z560 – 02.24.04	1

Lower frame with hydraulic system, set

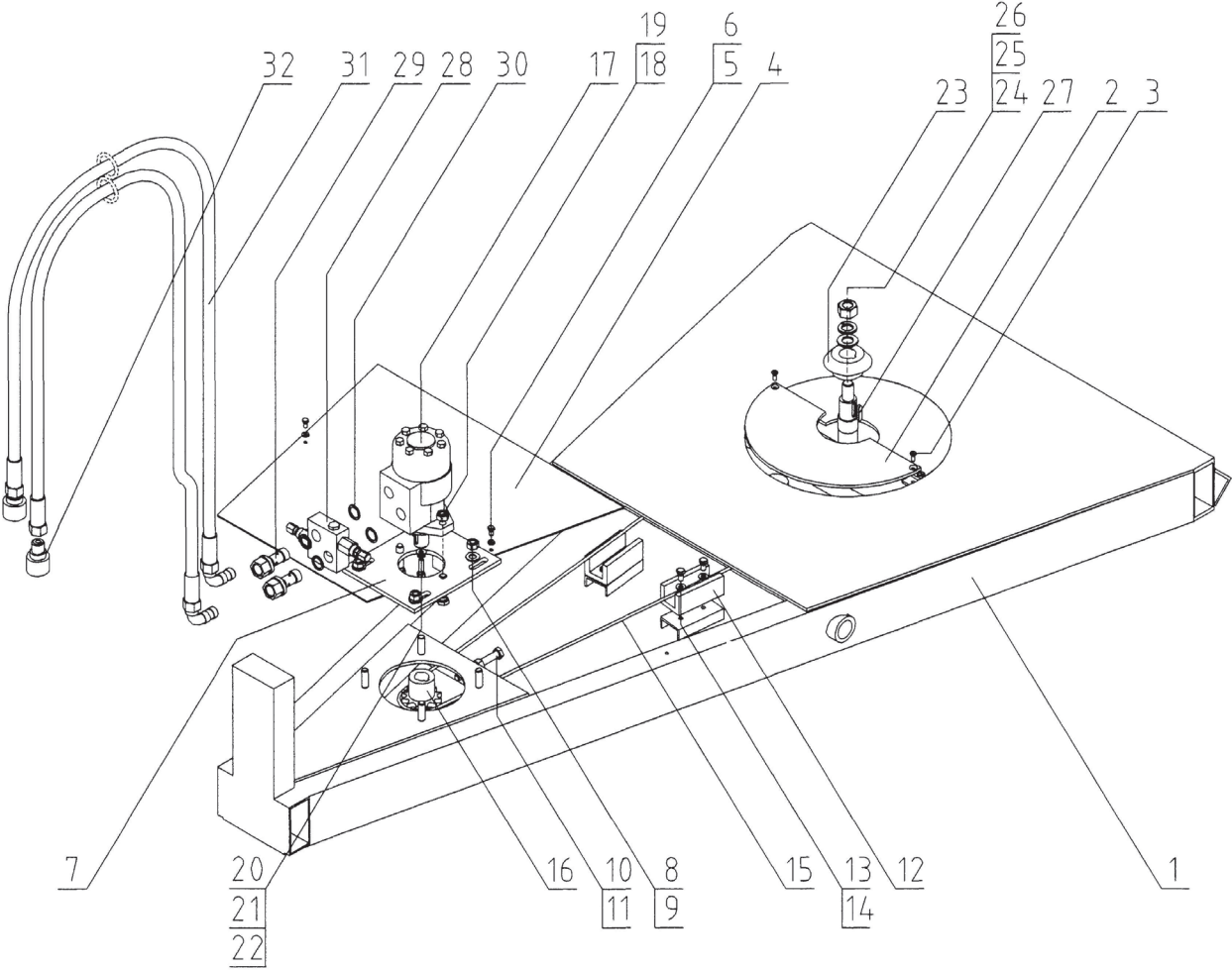

LOWER FRAME WITH HYDRAULIC SYSTEM 1/2

No. in dwg	Part name	Drawing no. or standard	Quantity
1	Chassis frame	Z560 – 03.00.00	1
2	Chain wheel guard	Z552 – 00.00.10	2
3	Screw, M6x16 8.8 – B	PN/M – 82209	4
4	Middle guard	Z552 – 00.00.14	1
5	Bolt, M6x16 5,8 – B	PN/M – 82105	2
6	Spring washer Ø6.1	PN/M – 82008	2
7	Engine base	Z552 – 00.09.00	1
8	Plain washer Ø13	PN/M – 82005	4
9	Nut, M12 5 – B	PN/M – 82175	4
10	Bolt, M12x100 5.8 – B	PN/M – 82105	1
11	Nut, M12 5 – B	PN/M – 82144	1
12	Chain guide	Z552 – 03.00.22	2
13	Screw, M8x20 5.8 – B	PN/M – 82209	4
14	Plain washer Ø8.4	PN/M – 82005	4
15	Chain, 10 – B	PN/M – 84168	1
16	Hydraulic motor	OMR 200 G1/2	1
17	Bolt, M12x45 8,8 – B	PN/M – 82105	2
18	Nut, M12 5 – B	PN/M – 82175	2
19	Bolt, M8x30 8,8 – B	PN-M – 82105	1
20	Spring washer Ø8.2	PN/M – 82008	1
21	Plain washer Ø10.5	PN/M – 82030	1
22	Bevel gear, Z – 17	Z552 – 00.00.13	1
23	Plain washer Ø21	PN/M – 82005	1
24	Spring washer Ø20.5	PN/M – 82008	1

Lower frame with hydraulic system, set

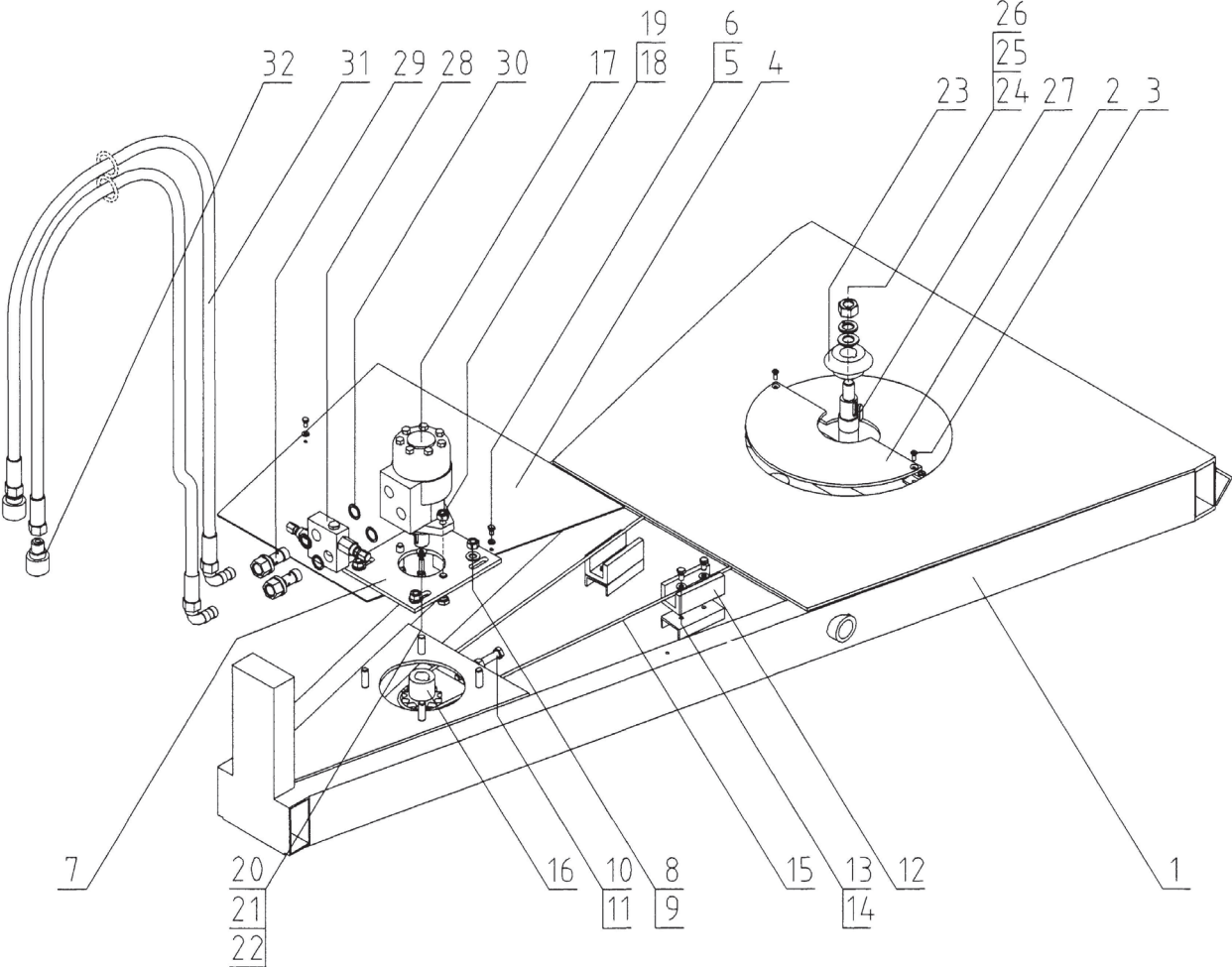

LOWER FRAME WITH HYDRAULIC SYSTEM 2/2

No. in dwg	Part name	Drawing no. or standard	Quantity
25	Nut, M20 5 – B	PN/M – 82144	1
26	Parallel key, A8x7x36	PN/M – 85005	1
27	Hydraulic block	ZP – 2 – 00/A Waryński	1
28	Hydraulic screw	Z552 – 00.00.23	2
29	Plain washer Ø20.5 Cu, hydraulic		4
30	Spacing bushing	Z560 – 00.00.62	1
31	Hydraulic hose	P12/P11 L = 2000	2
32	Valve – plug, quick-release coupling, M22x1.5	ZSR6 – 160 – 13/200	2
33	Gear wheel, Z – 12	Z560 – 00.00.08	1

Rotary frame 1/2

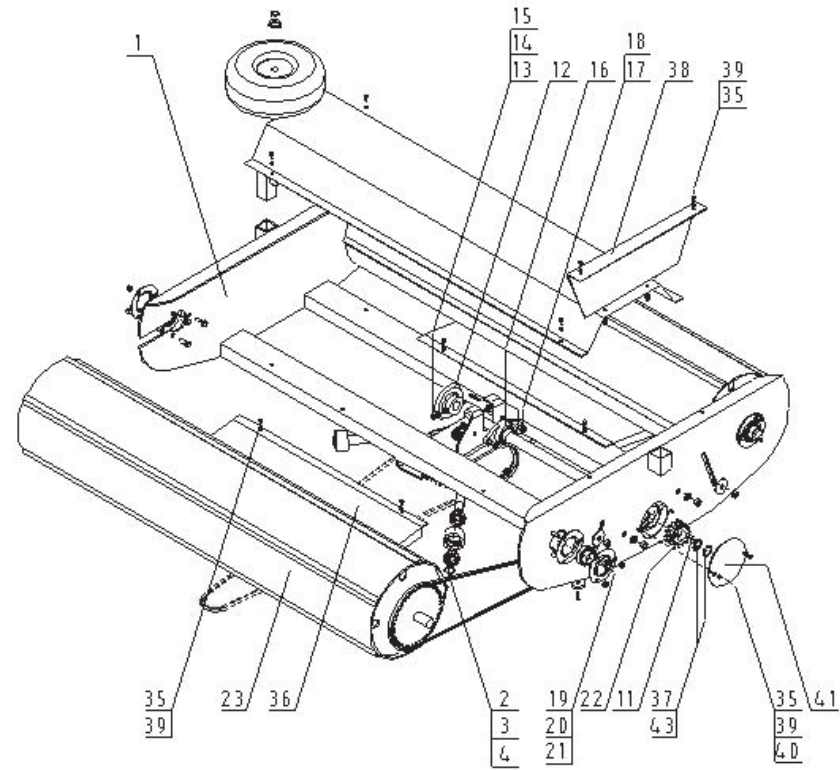

ROTARY FRAME 1/2

No. in dwg	Part name	Drawing no. or standard	Quantity
1	Rotary frame	Z560 – 04.00.00	1
2	Bearing, 6005 RS	PN/M – 86100	8
3	Bearing holder roll	Z560 – 04.00.09	4
4	Spring ring, Z – 25	PN/M – 85111	4
5	Revolution sensor magnet		1
6	Screw, M6x25 5.8 -B	PN/M – 82209	1
7	Nut, M6 5 – B	PN/M – 82144	1
8	Bearing, 6007 2RS	PN/M – 86100	2
9	Spring ring, W – 62	PN/M – 85111	1
10	Drive shaft	Z 560 – 00.00.11/I	1
11	Parallel key, A8x7x36	PN/M – 85002	2
12	Bevel gear, Z – 25	Z560 – 00.00.12	1
13	Bolt, M8x30 8,8 – B	PN/M – 82105	2
14	Spring washer Ø8.2	PN/M – 82008	2
15	Nut, M8 5 – B	PN/M – 82144	2
16	Bearing assembly, UCFL206	PN ISO 3228:1996	2
17	Bolt, M12x35 5,8 – B	PN/M – 82105	4
18	Nut, M12 5 – B	PN/M – 82175	4
19	Bearing, S A 206 RS	PN/M – 86100	4
20	Sheet metal flanged holder, P – 206	PN ISO 3228:1996	8
21	Nut, M10 5 – B	PN/M – 82175	12
22	Chain wheel, Z – 11	Z 560 – 00.00.16/I	1
23	Drum, set	Z560 – 06.00.00	2
24	Bolt, M10x30 5,8 – B	PN/M – 82105	6
25	Chain tensioner roll	Z560 – 00.00.56	1

Rotary frame 2/2

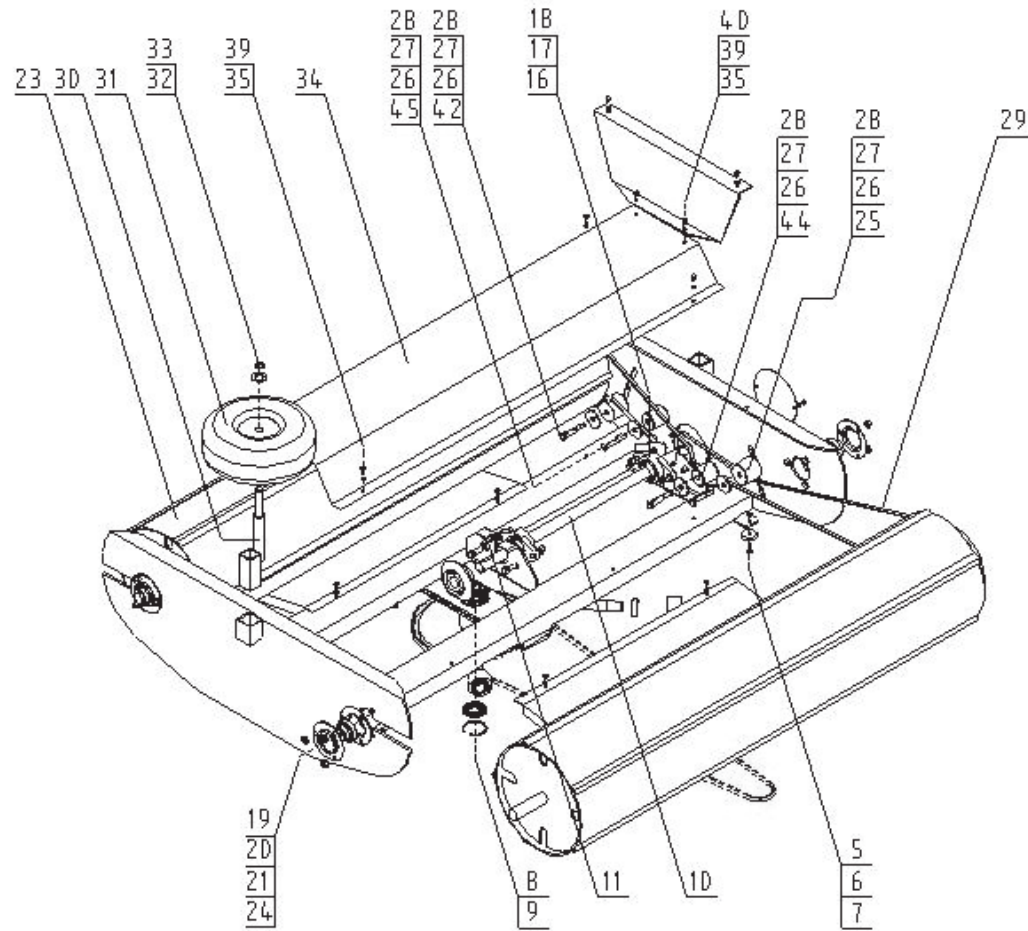

ROTARY FRAME 2/2

No. in dwg	Part name	Drawing no. or standard	Quantity
26	Bolt, M12x90 5.8 – B	PN/M – 82101	4
27	Nut, M12 5 – B	PN/M – 82175	4
28	Plain washer	G = 5/Ø13/Ø50	5
29	Chain, 10 B	PN/M – 84168	2
30	Wheel bracket	Z 560 – 05.01.00	2
31	Wheel with hub, 400x4		2
32	Plain washer Ø21	PN/M – 82005	2
33	Spring ring, Z – 20	PN/M – 85111	2
34	Middle guard	Z552 – 00.00.15	1
35	Bolt, M6x16 5,8 – B	PN/M – 82105	14
36	Bearing guard	Z552 – 00.00.18	2
37	Spring ring, Z – 25	PN/M – 85111	1
38	Drive guard	Z560 – 00.00.17	1
39	Spring washer Ø6.1	PN/M – 82008	14
40	Nut, M6 5 – B	PN/M – 82144	4
41	Cover	Z 560 – 00.00.60	1
42	Chain tensioner roll II	Z560 – 00.00.61	1
43	Plain washer	G =1.5/Ø26/Ø36	1
44	Chain tensioner roll III	Z560 – 00.00.63	1
45	Chain tensioner roll IV	Z560 – 00.00.64	1

Vertical bale positioning device

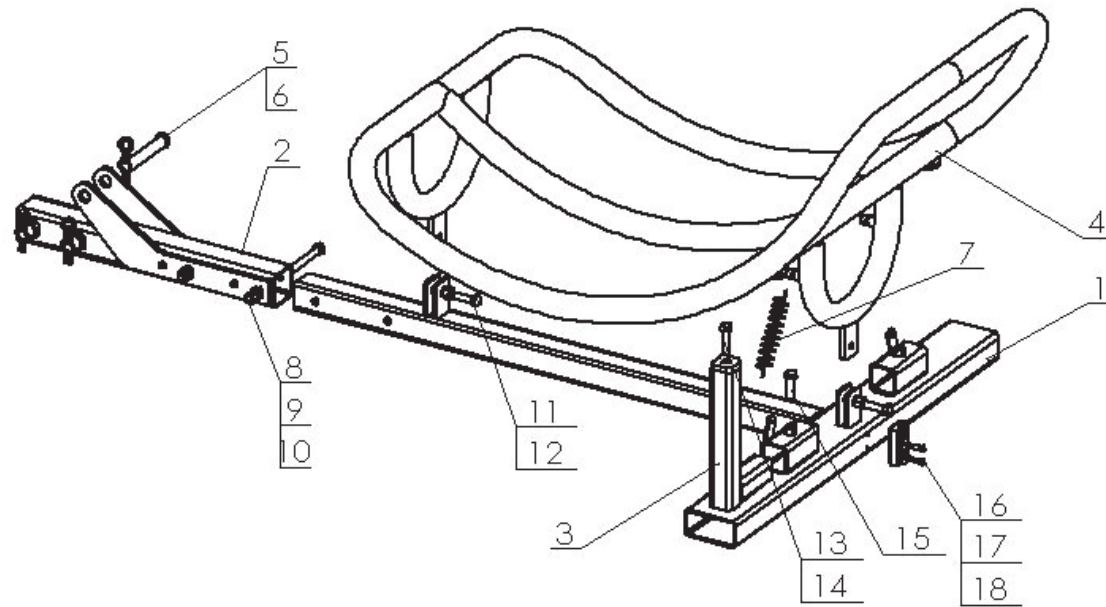

VERTICAL BALE POSITIONING DEVICE

No. in dwg	Part name	Drawing no. or standard	Quantity
1	Chassis frame	Z-552 19.01.00	1
2	Suspension	Z-552 19.02.00	1
3	Bumper	Z-552 19.03.00	1
4	Cradle	Z-552 19.04.00	1
5	Pin	Z-552 19.00.05	3
6	Cotter pin Ø6	DIN 11023	3
7	Spring I	Z-552 02.00.16	1
8	Bolt, M12x100 8.8-B	PN/M-82101	2
9	Nut, M12-8	PN/M-82144	2
10	Spring washer, 12.2	PN/M-82008	2
11	Bolt, M12x45 8.8-B	PN/M-82105	2
12	Nut, M12-8	PN/M-82175	2
13	Bolt, M12x30 8.8-B	PN/M-82105	1
14	Nut, M12-8	PN/M-82153	1
15	Bolt, M12x25 8.8-B	PN/M-82105	1
16	Triangle hitch		1
17	Bolt, M6x16 5.8-B	PN/M-82105	2
18	Plain washer, 6.4	PN/M-82005	2